

## APEX TOP ARM LOAD GAUGE

### USER'S MANUAL

In the box containing the gauge, you will find the following items.

- 1 The dial block
- 2 A pouchful of adaptors for various draftings. (and nuts and spanner)
- 3 A pad with roller pairs.

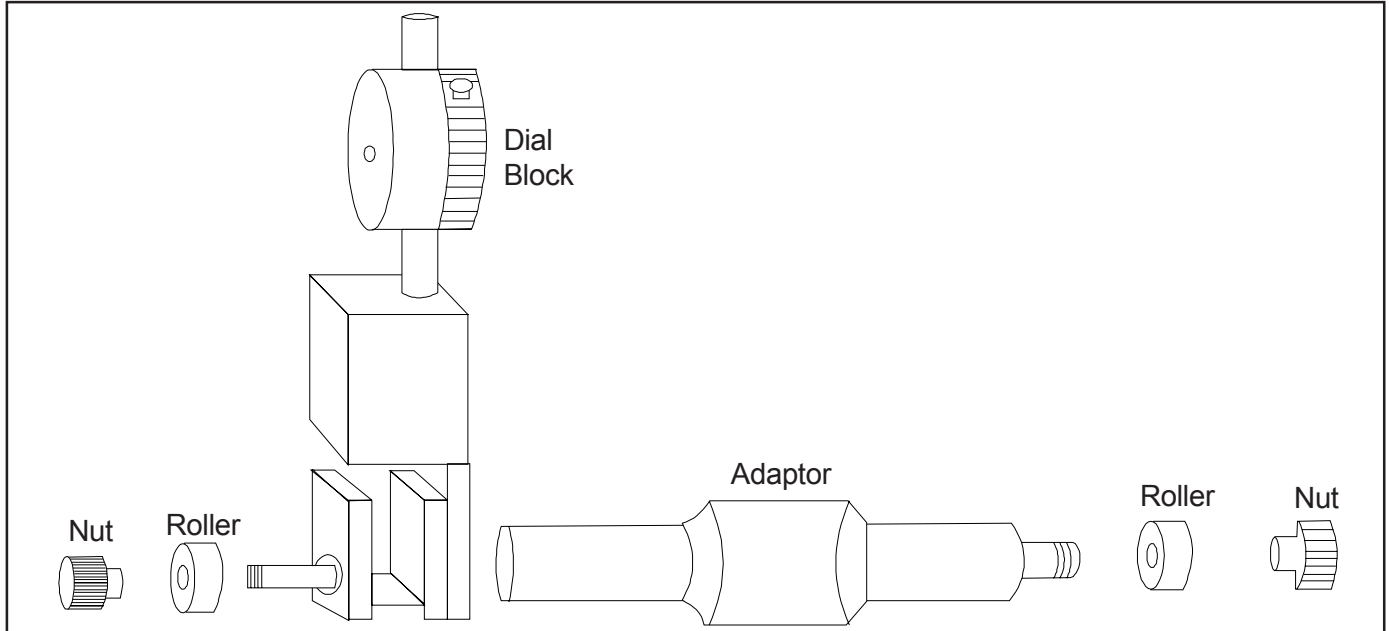

#### **ASSEMBLY**

- 1 Take the dial block. Take the suitable adaptor from the pouch. It has markings for the drafting like SKF PK 225, IR G5/1 etc.
- 2 Now, screw on the adaptor into the dial block and tighten with spanner
- 3 The roller pad has rollers with sizes embossed on the face. Now, from the roller pad, remove the roller pair of size very near to the cot size running in the mill. (Example if 28.4 is running, select 28.5, if 28.1 is running then select 28.0). Slide the roller one at each end of the present gauge adaptor assembly. (See fig. 1) Assemble in such a way that the size showing plate is at the extreme end.
- 4 Now take the two knurled nuts and screw them on each end. Tighten by hand.

#### **MEASUREMENT :**

Now this assembly resembles a top roller. To measure top arm loads follow the rules.

1. Ensure the load dial pointer is in zero position. If not, slightly tap the dial by the finger to see if it returns. If still not, loosen the lock nut by hand and slightly rotate the bezel in the appropriate direction till zero is achieved. Tap by finger again. Fine tune, if necessary. Then tighten the lock nut. Now your gauge is ready for measurement. (See fig for details). For every few hundred measurements, the zero may change. Then follow the same procedure.

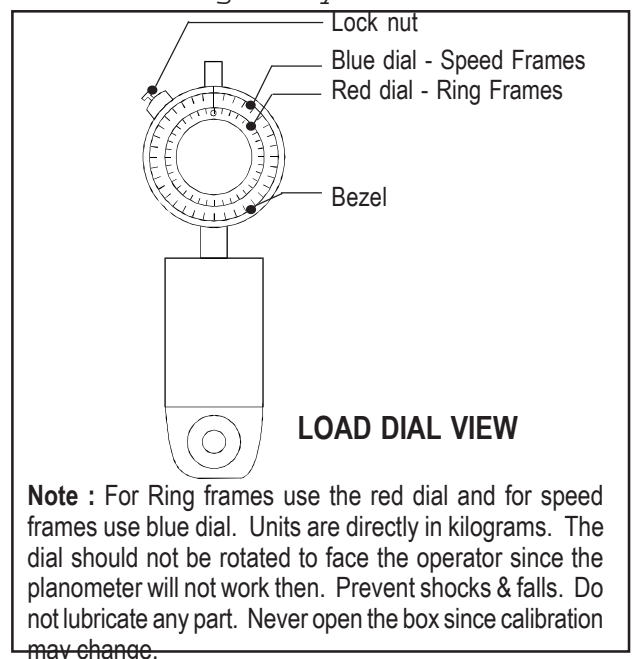

## MOUNTING ON TOP ARMS :

1. Select the top arm to be measured
2. Release the pressure lever of top arm and remove the front roller.
3. Now, replace the gauge in place of the top roller and snap it with the top arm. Hold the gauge by hand.
4. Holding the gauge, press the top arm lever.
5. Ensure correct inclination using planometer which is at the back of the load dial. see fig.

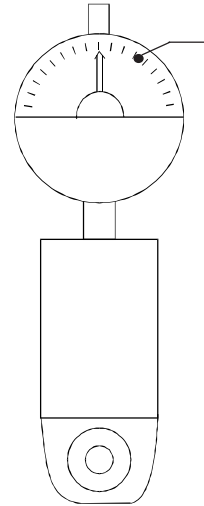

REAR VIEW - PLANO METER

**Note :** Planometer exploits gravitational force which helps its pointer to remain perpendicular to the earth. Before each measurement, ensure the pointer is meeting the marking for the respective top roller stand angle of the drafting by swinging to or fro. Usual angles are 30°, 45°, 60° degrees.

6. Now the deflection of the load dial in the specific scale (i.e. ring frame or speed frame) is recorded, before recording, tilt the gauge to and fro to set correct angle in planometer. The reading is noted. This will eliminate any fouling due to alignment problems. Repeat the same process from step 1 to 5 for each roller of the same top arm or different top arm. If corrections are carried over, check again. The user has the option of measuring when the machine is running or when idle. when running, the needle may oscillate.

## TROUBLE SHOOTING

If you doubt the loads indicated after prolonged usage, the gauge block can be sent to the factory. Recalibration becomes necessary when there is an impact load and suspicion of inner damage, or on unauthorised tampering, usual period between recalibration is 2 years.

2. In pneumatic draftings, erratic reading may be indicated when the hoses are wornout. Same top arm will give various readings on successive checks.
3. while checking for apron roller, the total of the shell plus twice the thickness of the apron has to be taken and the roller of respective diameter should be chosen.
4. While checking, all rovings and slivers should be removed from the bottom rollers since they may influence the load.

## THE MANUFACTURER'S RECOMMENDATIONS OF LOAD SETTING IN POPULAR TOP ARMS TABLED HEREUNDER

Name of Drafting	Front Roller Load	Middle Roller	Rear	Rear	Remarks
SKF PK 225*	10 Black	-	-	-	3 Roller ring frame drafting
	14 Green	10	14	-	
	18 Red				
SKF PK 211	8	7	5.4	-	3 Roller ring frame drafting
SKF PK 1600 - 40*	20 Black	10	10	10	4 Roller Speed frame drafting
	25 Green	15	15	15	
	30 Red	20	20	20	
WST UT 620	14	10	14	-	3 Roller ring frame drafting
WST UT M 620	16	12	14	14	4 Roller Speed frame drafting
LR G 5/1	16	14	16	-	3 Roller ring frame drafting
LR D J/5	14	10	14	-	3 Roller ring frame drafting
LR LF 1400	20	12	16	16	4 Roller Speed frame drafting
LR LF 1400A	20	12	16	-	3 Roller Speed frame drafting



**APEX PRECITECH**

2/36, Sri Ambal Nagar, Vilankurichy, (Near Cheran Maa Nagar),  
Coimbatore - 641 035. Ph. : 91 422 2667026