

## APEX DRAW FRAME TOP ROLLER LOAD GAUGE

### USER'S MANUAL

In the brief case, you will find

1. Two dial blocks - one for left and one for the Right
2. Adaptors for your machines and
3. Nylon Rollers to suit your rubber cots

### **ASSEMBLY**

1. Take the dial blocks from the box after releasing and place it on a table. Remove the protective plastic covers on ends.
2. Now, for the machine to be checked (e.g RSB, DO 6 etc) take the two appropriate end adaptors supplied. Slide them on to the lengthier rod side and push them till they touch the face.
3. Now, take the centre rod for the machine. Take also the Nylon rollers equal or nearly equal to the top roller cot on the machine. Push the rollers onto the ends of the centre rod.

**Note :** For RSB, VOUK, RETIER D 30, HARA 500 etc only one roller is given. In these systems, the centre rod and rollers have equal lengths.

4. This centre rod roller assembly is first slid on to the other smaller rod end of the left dial block. The other end of the centre rod fits with the right dial block. On completion, both the load dials will face the operator and there will be no gaps between dial block and centre rod. Keep the full assembly on the table gently.

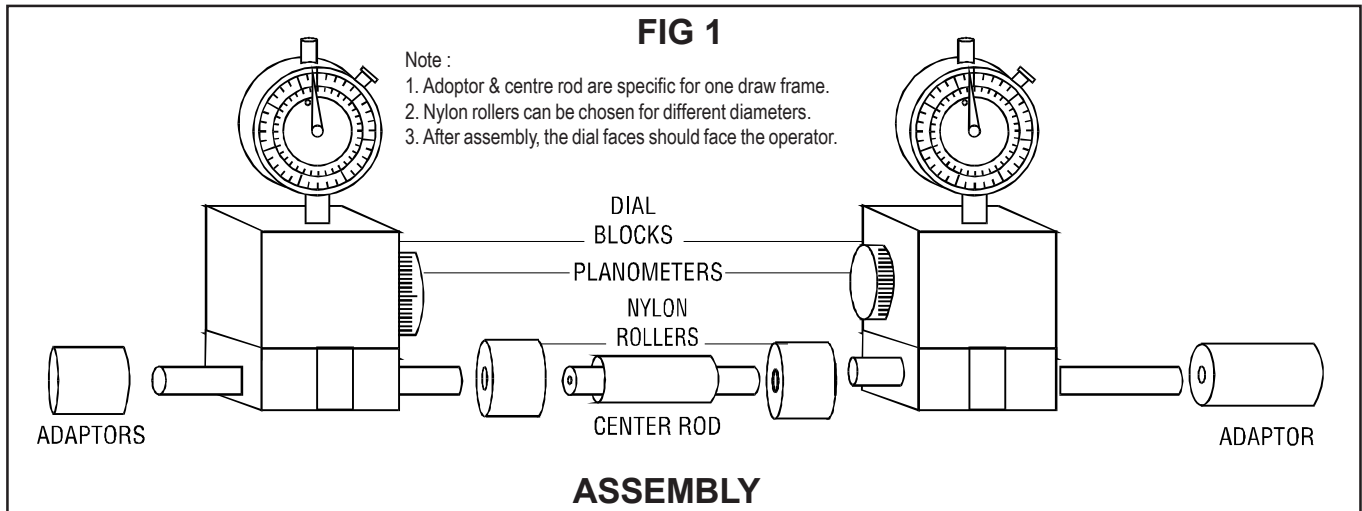

### **PREPARATION FOR MEASUREMENT**

1. Check whether the pointers are showing zero. If not, slightly tap the gauges with the fingers. If still not, loosen the locknut of the dial and rotate the bezel clockwise or anticlockwise to achieve zero, tap again when zero is set, tighten the locknut. This is the standard procedure for zero setting before every measurement. (See Fig 2 )

#### **Note :**

1. If zero is not coinciding with pointer slightly tap the dial with finger.
2. If still not, loosen the dial lock nut and adjust the bezel to achieve pointer and zero coincidence. Tap again, fine tune, Tighten.

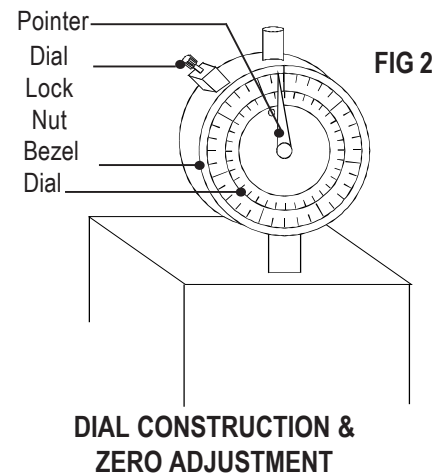

2. In the draw frame whose top roller loads are to be measured, remove the first top roller alone. Clean the bottom roller of all slivers and fluffs. Place the gauge in the saddle of the drafting as you will place the top roller. Hold gauge by hand. Now, apply the top arm load (Pneumatic or spring load). The pointer will deflect while checking. The planometer readings are to be kept at the appropriate angle of the stand inclination (For eg.) since RSB is a flat bed drafting, the planometer should read 0°. You will notice that swinging the gauge to and fro about the axis will change readings in planometer. swing twice, and then steady at the correct angle. The reading in each load dial is the end load of the drafting for that end. (See fig. 3.) Repeat step 1 and 2 for all rollers of the machine.

FIG 3

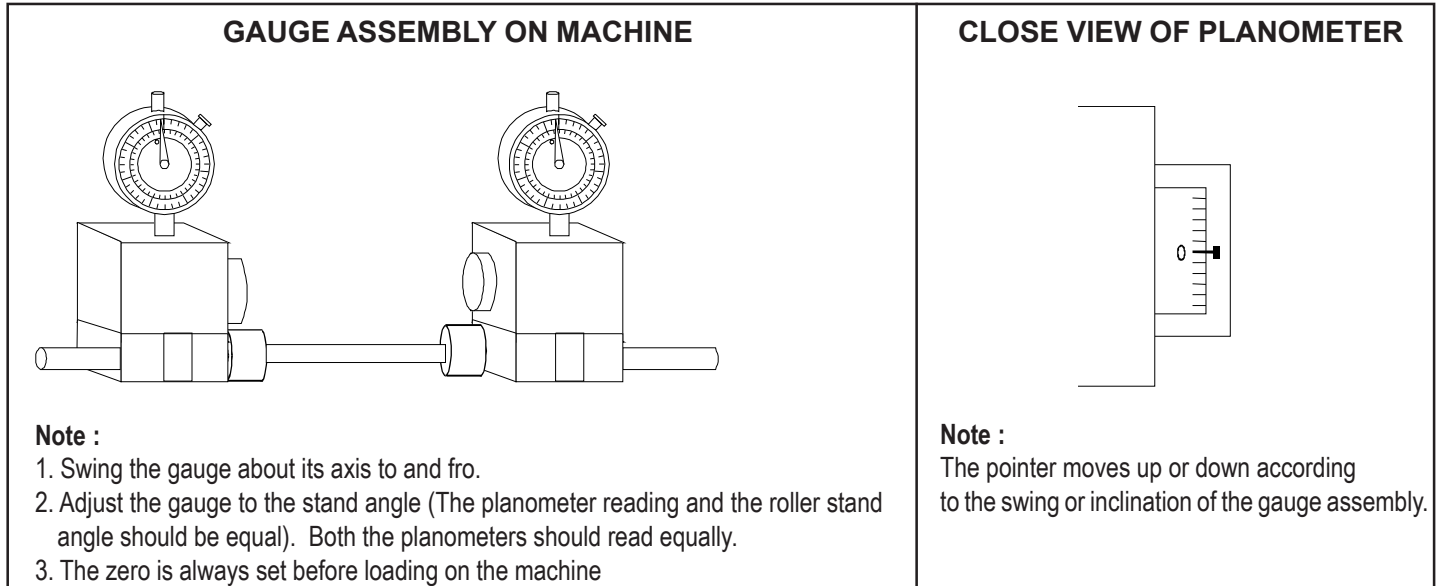

Selection of Scales : for various machines

Blue Scale : DO2S, DO6, E7/4, SLIVER LAP E2/4A, RIBON LAP E4/1A

Black Scale : RSB, HOWA DFK2CD, LK 250, PADMATEX, 4/3, 5/3, ZINSER720, 730, RETER D30

Red Scale : Vouk 802E, VS4, Hara 500, 600, Trutschler HSR 900, 1000

**LOAD SETTING VALUES IN POPULAR DRAW FRAMES**

Name of Machine	Top Roller End Loder				Remarks
	1st	2nd	3rd	4th	
LR DO2, DO2S D/F	40	40	40	--	Pneumatically loaded, 3 Roller Drafting
LR DO6 D / F	20	20	20	--	Pneumatically loaded, 3 Roller Drafting
RSB D/F	32	32	32	--	Spring Loaded, 3 Roller Drafting
Padmatex / Zinser 4/3 & 5/3 D/F	14	26	40	40	Spring Loaded, 4 & 5 Roller Drafting
VOUK D / F	32	32	32	--	Hydraulic Loaded, 3 Roller Drafting
HOWA D / F	10	35	35	35	Spring Loaded, 4 Roller Drafting
LRE7/4 COMBER	30	30	30	--	Pneumatically loaded, 3 Roller Drafting
LR SILVER LAP	22	5	25	--	Pneumatically loaded, 4 Roller Drafting
LR RIBBON LAP	30	20	20	--	Pneumatically loaded, 3 Roller Drafting

**SOME USEFUL HINTS**

1. The term drafting load or the Nip Load of a top roller is always the sum of the end loads.
2. In pneumatic draftings like DO2S, DO6, E7/4, E2/4A, E4/1A, while measuring, the pointer may not move up smoothly while applying pressure and may not release smoothly when air is cut off. This may be because of problems with the pressure hose. New hose replacement or the hook set will solve the problem.
3. In RSB (All models) being a spring loading system the end loads can be equalised by moving the hooks up and down. When 39mm diameter cots are used the user may get 32.5kg load per end. As the size decreases, the loads may drop, but can be increased equally by using the hooks.
4. For Padmatex machines 4/3 & 5/3 (Zinser 720)

The adapter for 5/3 and 4/3 are same for 1st, 2nd and last rollers. For 3rd roller it is different. The loads may be varied by using the tightening nut in the spring loading assembly at each end. If, after full tightening of the nut, the load is not reached, new springs may be used.



**APEX PRECITECH**

2/36, Sri Ambal Nagar, Vilankurichy, (Near Cheran Maa Nagar),

Coimbatore - 641 035. Ph. : 91 422 2667026

e-mail : apexpreci@eth.net

Website : www.apexprecitech.com