

APEX COMBER DETACHING ROLLER LOAD GAUGE USER'S MANUAL

In the brief case, you will find

1. Two dial blocks –one for left and one for the Right
2. Adaptors for your machines and
3. Nylon Rollers to suit your rubber cots

ASSEMBLY

1. Take the dial blocks from the box after releasing and place it on a table . Remove the protective plastic covers on ends.
2. Now, for the machine to be checked (e.g. E7/4, LK250 etc) take the two appropriate end adaptors supplied. Slide them on to the lengthier rod side and push them till they touch the face.
3. Now, take the centre rod for the machine. Take also the Nylon rollers equal or nearly equal to the top roller cot on the machine. Push the rollers onto the ends of the centre rod.
4. This centre rod roller assembly is first slid on to the other smaller rod end of the left dial block. The other end of the centre rod fits with the right dial block. On completion, both the load dials will face the operator and there will be no gaps between dial block and centre rod. Keep the full assembly on the table gently.

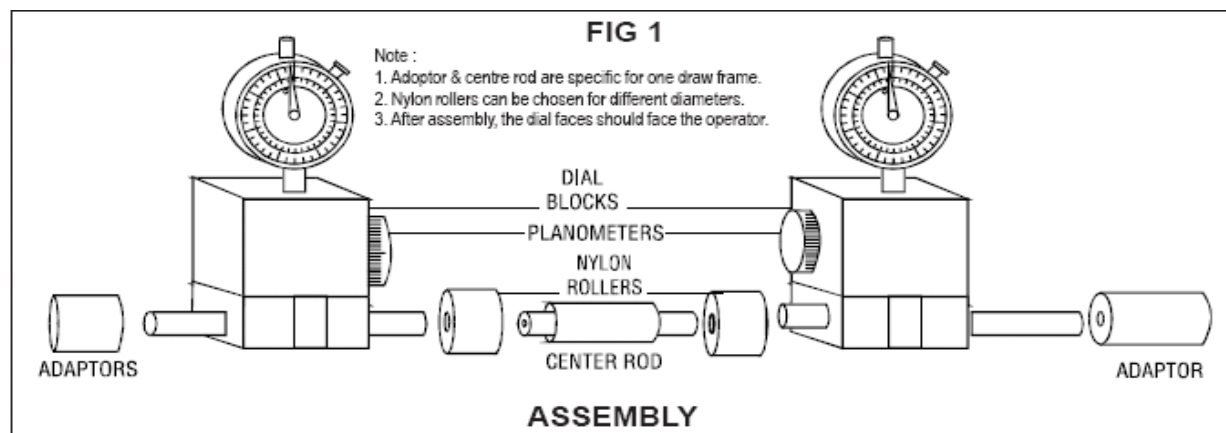

PREPARATION FOR MEASUREMENT

1. Check whether the pointers are showing zero. If not, slightly tap the gauges with the fingers. If still not, loosen the locknut of the dial and rotate the bezel clockwise or anticlockwise to achieve zero, tap again when zero is set, tighten the locknut. This is the standard procedure for zero setting before every measurement.(see Fig 2)

Note :

1. If zero is not coinciding with pointer slightly tap the dial with finger.
2. If still not, loosen the dial lock nut and adjust the bezel to achieve pointer and zero coincidence. Tap again, fine tune, Tighten.

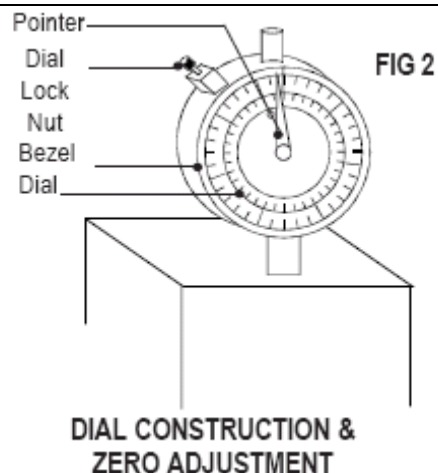

2. In the comber whose detaching roller loads are to be measured, remove the first top roller alone. Clean the bottom roller of all silvers and fluffs. Place the gauge in the saddle of the drafting as you will place the top roller. Hold gauge by hand. Now, apply the top arm load (Pneumatic or spring load). The pointer will deflect while checking. The Planometer readings are to be kept at the appropriate angle of the stand inclination. You will notice that swinging the gauge to and fro about the axis will change readings in Planometer. Swing twice and then steady at the correct angle. The reading in each load dial is the end load of the drafting for the end. (see fig.3) Repeat step 1 and 2 for all roller of the machine.

FIG 3

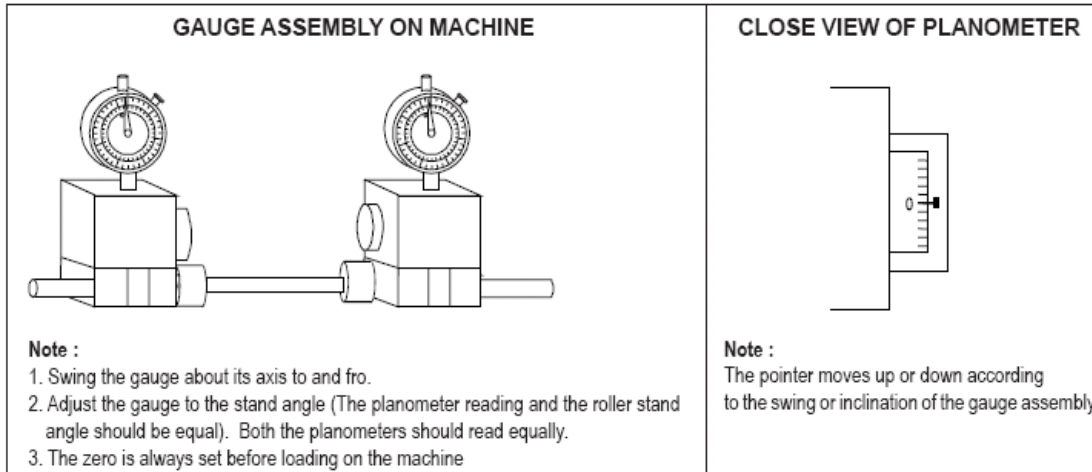

SELECTION OF SCALES FOR VARIOUS MACHINES

Red Scale :E 7/4, E 7/5, E7/6, E60, E62 , LK 54, VC 300, 300A
 Bule Scale : LK 250

LOAD SETTING VALUES IN DETACHING ROLLERS OF POPULAR COMBERS

Machines/Model	Load, Kg		Angle
	1	2	
E 7/4	8	8	0
E 7/5,5A,60, E60 , E 62	13	14	0
LK 250 (Old)	12	14	0
LK 250 New	6	6	0
VC 300, 300A	20	17	0
LK 54	14	16	0

APEX PRECITECH

2/36, Sri Ambal Nagar, Vilankurichy, Coimbatore- 641 035. India
 Tel: 91 422 2667026,2666292, 5543298 Fax : 2667026, Email: apexpreci@eth.net
 Website : www.apexprecitech.com